

SONA COLLEGE OF TECHNOLOGY
Learning is a Celebration!

| An Autonomous Institution |

**Department of Electronics and
Communication Engineering**



WORLD IN SECONDS

2017-18



Junction Main Road
Suramangalam (PO)
Salem-636 005. TN. India
www.sonatech.ac.in

EDITOR'S BOARD

Editorial Head

Dr.R.S.Sabeenian,
Professor &Head, Dept of ECE,
Head R&D Sona SIPRO.



Editorial members:

1. Dr.R.Vinod Kumar,
Professor



2. Dr.G.Ravi,
Assistant Professor



3. Ms.S.Vijayashaarathi,
Assistant Professor



Magazine Coordinator

M.Senthil Vadivu,
Assist.Professor



Student Members:

1. R.Dhinesh



2. M.Tharani



Preface

The Communication Systems and Networks (CSN) is an inter-disciplinary group focusing on cutting-edge research in the development of reliable and efficient delivery of information for future Internet. It encompasses several areas of study including, but not limited to, telecommunication engineering, mobile communication, sensor networks, intelligent algorithms, network security and bio-inspired networks. The thrust of the research is in the development of intelligent protocols and architectures that offer seamless support for a variety of applications and user requirements in next generation networks. Work under this group includes algorithm design, protocol development and analysis, network programming, and prototype development. The main objective of the group is to establish a world-class collaborative research environment.

Li-Fi

Sindhuja – IV Year

The most important day-to-day activities in this fast world are the transfer of data and information. As the world is becoming faster the need of fast data transmission is also increasing. As the numbers of devices that access to the internet are increasing, the limited bandwidth leads to decrease in the speed of the data transfer.

To give a solution to this problem Li-Fi technology is introduced. Li-Fi stands for Light Fidelity. Li-Fi provides better bandwidth, efficiency, availability and security than Wi-Fi and thus increases the data transfer speed. Li-Fi technology provides transmission of data through illumination by taking the fibre out of fibre optics by sending data through an LED light bulb that varies in intensity faster than the human eye can follow. Li-Fi is ideal for high density wireless data coverage in confined area and for relieving radio interference issues.

Lifi uses visible light instead of Gigahertz radio waves for data transfer which makes it fast and cheap mode of wireless communication. The idea of Li-Fi was introduced by a German physicist, Harald Hass, which he also referred to as —data through illumination|. The term Li-Fi was first used by Haas in his TED Global talk on Visible Light Communication. According to Hass, the light, which he referred to as D-Light, can be used to produce data rates higher than 10 megabits per second which is much faster than our average broadband connection.



Li-Fi Bulb

Constructions of Li-Fi System

The LIFI™ product consists of 4 primary sub-assemblies:

- Bulb
- RF power amplifier circuit (PA)
- Printed circuit board (PCB)
- Enclosure

The PCB controls the electrical inputs and outputs of the lamp and houses the microcontroller used to manage different lamp functions. An RF (radio-frequency) signal is generated by the solid-state PA and is guided into an electric field about the bulb. The high concentration of energy in the electric field vaporizes the contents of the bulb to a plasma state at the bulb's centre; this controlled plasma generates an intense source of light. All of these subassemblies are contained in an aluminium enclosure.

Functions of the Bulb Sub-Assembly

At the heart of LIFI is the bulb sub-assembly where a sealed bulb is embedded in a dielectric material. This design is more reliable than conventional light sources that insert degradable electrodes into the bulb. The dielectric material serves two purposes; first as a waveguide for the RF energy transmitted by the PA and second as an electric field concentrator that focuses energy in the bulb. The energy from the electric field rapidly heats the material in the bulb to a plasma state that emits light of high intensity and full spectrum.

A COMPARISON BETWEEN Li-Fi, Wi-Fi, AND ETHERNET STANDARDS

O.Priya – IV Year

There has been a drastic change in how mobile communication devices are being used with data transfer and with mobility scenarios. Mobile users have been trafficking more data than voice while using these mobile devices leading to change of communication environment.

The vast number of mobile devices as well as the rapid growth of subscribers are evident. Also, it worth noting that the mobile PCs, tablets, and routers growth is much slower than mobile broadband devices and smart phones. To support the aforementioned growth, new connectivity technologies have emerged in the communication market. These include the LiFi, WiFi, and Ethernet technologies which follow various standards on how systems are built and how they communicate. The features list and differences between the LiFi and WiFi technologies are listed in Table . These three technologies are focused on high speed communications and would be interesting to compare these techniques against each other.

<i>Feature</i>	<i>LiFi</i>	<i>WiFi</i>
Full form	Light Fidelity	Wireless Fidelity
Operation	LiFi transmits data using light with the help of LED bulbs.	WiFi transmits data using radio waves with the help of WiFi router.
Interference	Do not have any interference issues similar to radio frequency waves.	Will have interference issues from nearby access points (routers)
Technology	Present IrDA compliant devices	WLAN 802.11a/b/g/n/ac/ad standard compliant devices
Applications	Used in airlines, undersea explorations, operation theaters in the hospitals, office and home premises for data transfer and internet browsing	Used for internet browsing with the help of WiFi kiosks or hotspots
Advantages	Interference is less, can pass through salty sea water, works in dense region	Prone to interference, can't pass through sea water, works in less dense region
Privacy	light is blocked by the walls, therefor more secured on data transfer	For RF signal, dry walls are transparent, therefore need to employ techniques to achieve secure data transfer.
Data transfer speed	About 1 Gbps	WLAN-11n offers 150Mbps, About 1-2 Gbps can be achieved using WiGig/Giga-IR
Frequency of operation	10,000 times frequency spectrum of the radio (In the Tera Hz range)	2.4GHz, 4.9GHz and 5GHz

ETHERNET

The Ethernet standards is a well-established technology that was released commercially during 1980 as the IEEE802.3. It has been a relatively inexpensive, reasonably fast, and very popular LAN technology for several decades [2]. The most commonly installed Ethernet systems are called 10BASE-T and provide transmission speeds up to 10 Mbps. Ethernet data transfer rates have been increased from the original 2.94(Mbit/s) to the latest 100 (Gbit/s). Jorg Sommer et. al. [3] have investigated fields of Ethernet applications and found them concentrated on three major categories:

- The operated and managed networks of carriers in the core and access part of a public or private network;
- The embedded networks in the manufacturing environment, in aircraft, and in cars;
- The home entertainment (AVB) networks residing between LAN and category two.

WiFi

WiFi - is a short name for Wireless Fidelity, and this system was released during 1990 with standard IEEE 802.11. This technology was designed to provide wireless connectivity to devices that require a quick installation, such as portable computers PDAs or generally mobile devices inside a WLAN network [4]. Table 3 provide more insight to the IEEE802.11 various components specifications.

Li-Fi

The LiFi considered as a WiFi with light being using light technology instead of Radio waves. It forms a new class of high intensity light source of solid state design bringing clean lighting solutions to general and specialty lighting. With energy efficiency, long useful lifetime, full spectrum and dimming, LiFi lighting applications work better compared to conventional approaches. The LiFi provide high efficiency communication system within confined spaces when compared to the WiFi, hence the two technologies can be considered complimentary.

The LiFi system uses standard LED light bulbs which are controlled by a driver that turns the LED on and off, or dims and brightens its light intensity. With Li-Fi enabled LED light bulbs, the driver is used to transmit encoded data by controlling the LED light. An optical sensor is used to receive the data, which is then decoded. This is conceptually similar to Morse code – but at rates of many millions of times a second, which is unperceivable to the human eye. The receiver has optics, and is fast enough to see the light dimming and brightening, smart enough to decode the Li-Fi data, and then deliver it to the attached device such as a laptop computer. Devices can include both a transmitter and receiver to enjoy two-way communications.

LI-FI (LIGHT FIDELITY): THE FUTURE TECHNOLOGY IN WIRELESS COMMUNICATION

Santhiya.S. – IV Year

Li-Fi is a VLC, visible light communication technology, developed by the team of scientists including professor Haas at the University of Edinburg and deals with transfer of data through illumination by taking fiber out of optics by sending data through a LED light bulb that varies in the intensity faster than a human eye can.

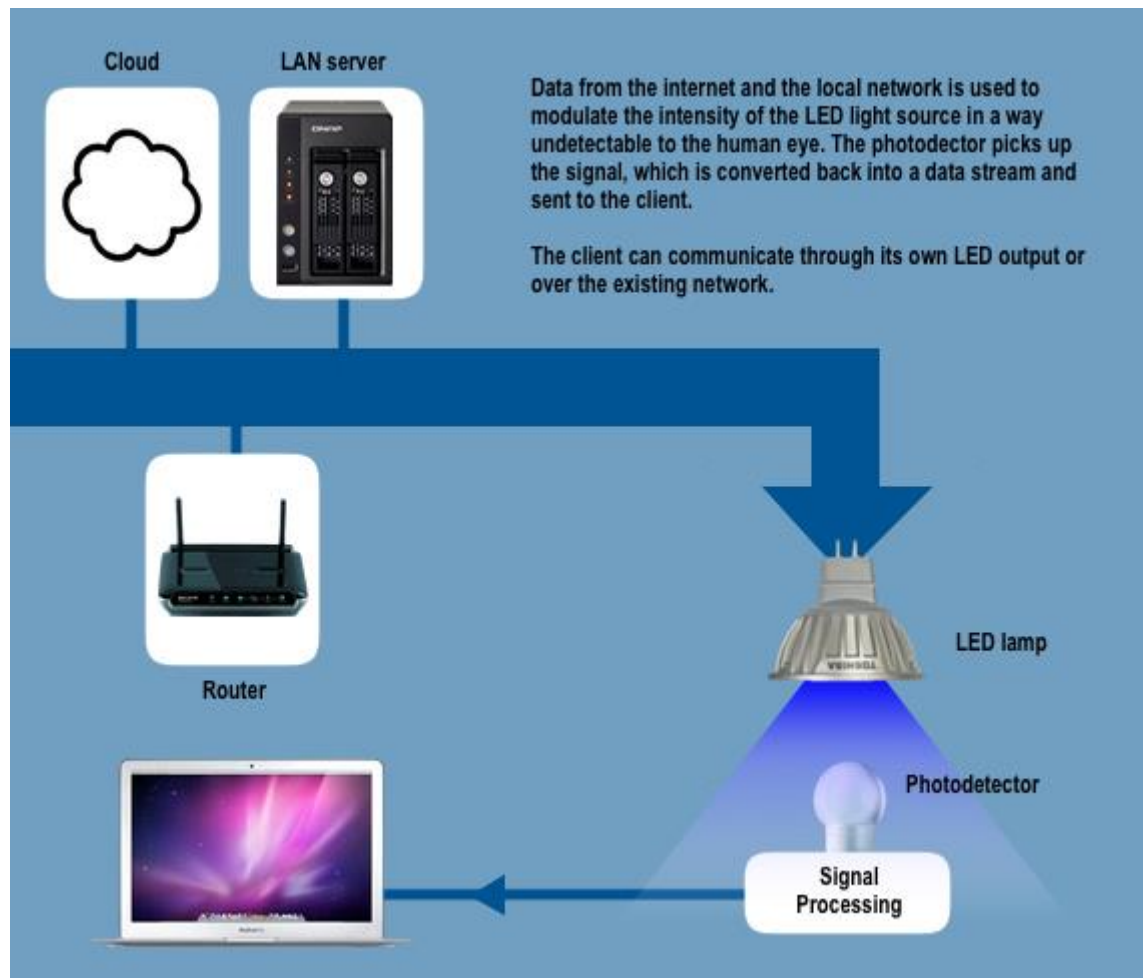

Genesis of Li-Fi

At TED global demonstration by Haas, where he achieved 10 mbps transfer rate increasing it further to 123 mbps after a month, he successfully demonstrated it by blocking the light source to block the video content received by the projector. Depleting bandwidths and faster data rates are major factors leading to further exploration of this utilitarian technique.

How it works

It is implemented by using a light bulb at the downlink transmitter. Normally the light bulb glows at a constant current supply however fast and subtle variations in current can be made to produce the optical outputs since it just uses the light, hence can be easily applied in aircrafts or hospitals or any such area where radio frequency communication is often problematic. The operation procedure is very simple-, if the LED is on you transmit a digital 1, if it is off you transmit a 0. The LED can be switched on and off very quickly hence providing nice opportunities to transmit data. Hence all that is required is some LED and a controller that code data into those LEDs flicker depending upon the data we want to encode. The more LEDs in your lamp, the more data it can process. To further get an clear idea of what is said above let us consider a IR remote which sends data stream at rate of 10000-20000 bps. Now replace the IR LED with a light box containing a large LED array which is capable of sending thousands of such streams at very fast rate. LEDs are found in traffic and street lights, car brake lights, remote control units and countless other applications. So visible light communication not only solves the problem related to lack of spectrum space but also enable novel application because this spectrum is unused and not regulated thus can be used for communication at very high speeds. This method of using rapid pulses of light to transmit information wirelessly, technically referred to as visible light communication (VLC) has a potential to compete with Wi-Fi and hence inspired the characterization of Li-Fi.

Transfer medium (fiber optic)

Generally, fiber optic cables are a wire that transmits data through a extremely thin layer of glass or plastic fiber threads. The relation between fiber optic thread and Li-Fi is that light signals travel through these fibers in form of light and then translated to 1's and 0's, the data part. However fiber optics are extremely expensive but massive bandwidth availability can do away with that and hence may soon replace most existing wired cables and the change has already started initiating.

LI-FI OVER WI-FI IN INTERNET DATA COMMUNICATION

Saramma.Z – IV Year

Internet data communication is a crucial activity for modern society. Since internet communication needs secure, efficient and high data rate communication, researchers propose different form of internet data communication. The current wireless data communication, Wireless-Fidelity, is based on radio frequency and uses router for signal transmitter and Wi-Fi card or chip as receiver which are built in modern computers and smart phones. This radio frequency based technology is limited in bandwidth, interfered with signals of different electronic equipment and easily accessed or hacked by unwanted hidden peoples. Light Fidelity (Li-Fi) is a new technology that uses illumination for internet data communication and will be implemented in a near future. Li-Fi uses semiconductor diodes for both data source and data receiver. It uses different color light emitting diodes (LEDs) as a transmitter and photodiodes as a receiver which are connected with computers or smart phones. Li-Fi technology uses the very simple technique of transmitting data using LED bulbs i.e. if the LED is ON, then the digital signal 1 is transmitted else if the LED is OFF, the digital signal 0 is transmitted which are detected by the photodiode at the receiver side. Li-Fi has many advantages over wireless fidelity (Wi-Fi). The advantage of Li-Fi over Wi-Fi is due to data communication spectrum differences. The electromagnetic spectrum bandwidth used for visible light communication (VLC) of Li-Fi is 10,000 times greater than for electromagnetic spectrum bandwidth of radio frequencies for Wi-Fi. Li-Fi technology has many advantages over Wi-Fi as a result of its unlimited bandwidth, its poor object penetration capacity, its low electromagnetic interference property and its possibility to integrate with the existing light infrastructure. But Li-Fi technology has some draw backs than Wi-Fi due to its radiation range, radiation direction and penetration capacity through objects and opaque materials. Since Li-Fi is clean, cheaper, and efficient and secure, most computer related companies will join and the draw backs will be reduced.

Li-Fi operation

Li-Fi uses the visible light communication (VLC) as the means of data transmission rather than the overly used radio waves by using white LED light bulbs to transmit the information as well as fulfilling the purpose of illumination. Through fast and slight variations of the current (which is applied to the LED), the optical output can be made to vary at very high speeds. The variation caused in the current which is passed to the LED.

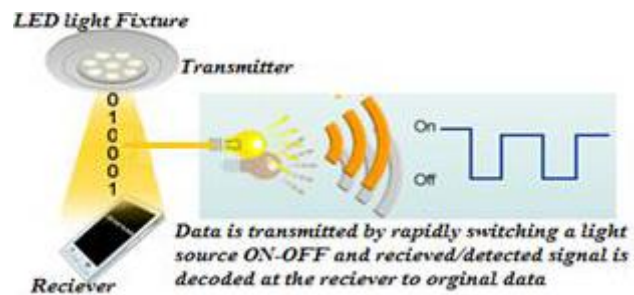

Li-Fi technology can be demonstrated to transmit data in bi-directional way. This demonstration was implemented by using LEDs bulb as data source from data source computer after converting to stream of ones and zeros data at modem or transceiver. This light data was detected by the light sensor screen at in front of light source bulb and converted to original data and displayed move at user computer. Li-fi uses two main section, transmitter and receiver, for reliable data transfer. Both transmitter and receiver use semiconductor diode, light emitting diode and light sensor/detector diode respectively. A transmitter at one end of the communication link sends a modulated signal and then a receiver at the other end detects the modulated light, converts it back to Zeros and Ones, and decodes the digital messages and data.

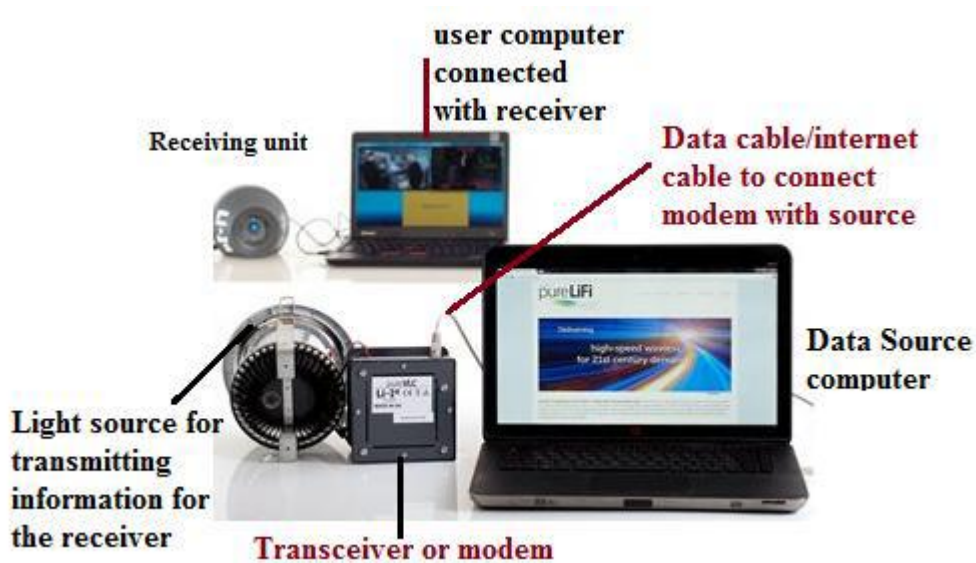

The input data from the source computer is converted to bits, zeros and ones, to represent as digital signal. Depending on this stream of digital ones and zeros data, the high illuminated LED bulb ON-OFF condition is controlled with the help of driver circuit. This highly flickered LED light is transmitted to the nearby receiver, photodiode. This weak received signal

is the amplified and the converted to binary signal of ones and zeros. Finally this converted zeros and ones stream data is read by the receiver computer or device.

Transmitter section

This section of visible light internet communication is designed for transmitting encoded signal to the receiver part by accepting data from the internet service providers as the form of light. Data from the sender is converted into an intermediate data representation i.e. byte format and then converted into light signals which are emitted by the transmitter. This given Li-Fi transmitter can be generalized as follows.

Source Computer - Data Reading Module - Data Conversion Module - Transmitter Module

Data Conversion Module – converts data into bytes so that it can be represented as a digital signal. It can also encrypt the data before conversion. It uses data converters and microcontroller unit as encoder or modulator.

Transmitter Module – generates the corresponding on off pattern for the LEDs by the help of driver circuit. Currently, there are different companies working on transmitter of this technology.

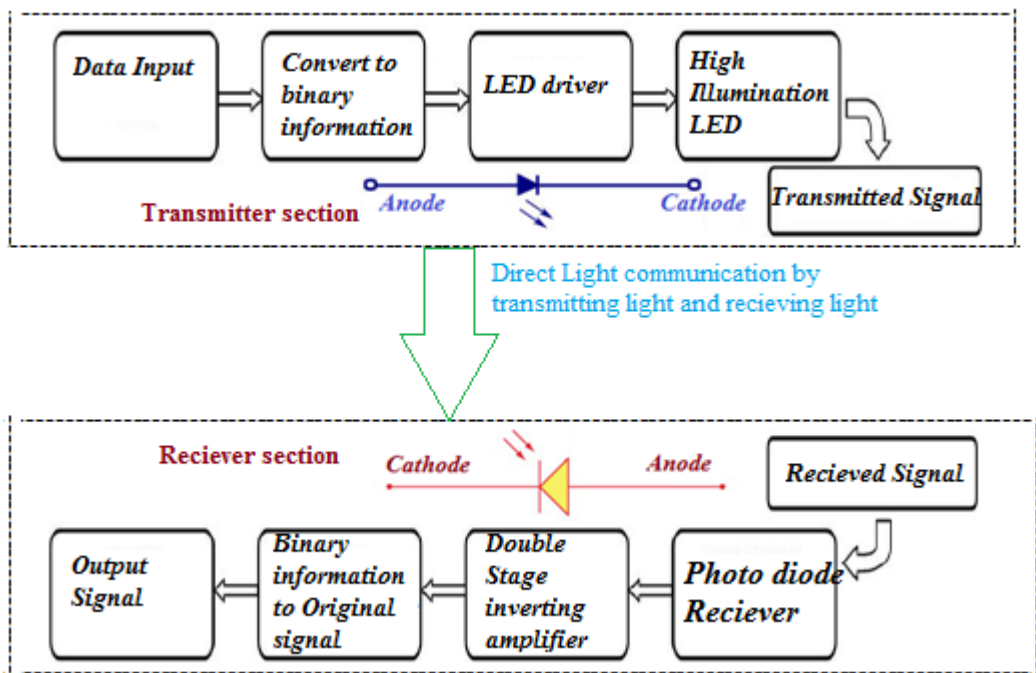

Each Lamp of the transmitter contains many in number and different in color, to increase the data rate, LEDs which are becoming smaller in size and faster in flashing. The Scottish researchers are developing micro-LEDs that are just $1\mu\text{m}^2$ (1000 times smaller) and 1,000 times faster in flickering, would be able to transmit data a million times faster than a normal LED. The efficiency of normal LED is almost 50 times greater than simple tungsten lamp and the response time is in the range of 0.1 microseconds when compared with 100 milliseconds for a tungsten lamp. The visible lights that an LED emits are usually orange, red, yellow, or green and blue color which is recently invented. The light signal is received by the photodiode at the receiver side. The main components of a receiver can be generalized as follows.

Destination Computer - Receiver Module - Data Interpretation Module - Data Display (GUI)

Receiver Module – has a photo diode to detect the on and off states of the LEDs. It captures this sequence and generates the binary sequence of the received signal and boosts this received signal by using amplifier.

Data Interpretation Module – detects and decodes or converts data into the original digital signal format with the help of microcontroller unit. If encryption was done at transmitter, it also performs decryption.

APPLICATIONS ON LI-FI

Dhamodaran – IV Year

Health technologies

For no longer time now medical technology would lag behind the rest of the wireless world. Till now operating rooms did not allowed Wi-Fi over radiation concerns, and there was also a whole lack of dedicated spectrum. Also if Wi-Fi is implemented in many hospitals, interference from cell phones and computers can block signals from monitoring equipment. Thus Li-Fi solves both problems: lights are not only allowed in operating rooms, but tend to be the most intended fixtures in the room. And, as mentioned by Haas in his TED Talk, Li-Fi has 10,000 times the spectrum of Wi-Fi, so we can't delegate red light to priority medical data.

Airlines

Airline Wi-Fi wants captive audience to pay for the "service" of dial up on the plane. And also they are very expensive. Passengers will soon be offered a "high-speed like" connection on some airlines. Li-Fi could easily introduce that sort of speed to each passengers reading light. It would be interruption free to and from other wireless signals on the board.

Power Plants

Wi-Fi and many other radiation or radio waves are bad for sensitive areas like those of power plants especially the atomic power plants. Nuclear power plants need fast, inter-connected data systems to monitor things like demand, grid integrity and core temperature. Proper monitoring can save huge benefits in terms of energy and economy obviously. Li-Fi could offer safe, abundant connectivity for all areas of these sensitive locations. This would be cost effective as well as would improve upon the current implementations solutions.

Under sea working

Underwater Rovers, also called toys of treasure seekers, operate from long cables that supply their power and allow them to receive signals from their pilots above. ROVs work efficiently until unless they got stuck somewhere or if the search area is huge. If made wireless and replaced with light — say from a submerged, high-powered lamp— then they would be free to explore more. They could also communicate with each other via headlamps, process

intermediate data autonomously and periodically refer back to the surface, all the while obtaining their next batch of orders from the source.

Information Delegation

Suppose your town is hit by earthquake and an average resident is not aware of such disastrous situations and precautions to be taken. Until he pass under a street light, he won't be aware of the emergency broadcasts. Remember, with Li-Fi, you're online only till its light. Subway stations and tunnels, common dead zones for most emergency communications, pose no obstruction and could opt to provide cheap high speed Web access to every street corner.

Learning

Lecture Halls Can Be Fun. Okay, well maybe not fun, but better. A few teachers tell me to download lecture notes from their blog in my time. Half the time I wished I already had the notes with me so that I could follow along as the lecture progressed. Imagine how interactive the classroom could be with real-time interconnectivity between 500 devices [8].

GPS usage

Satellite navigation has been one of the most important technological advances of the last 50 years. No matter how good the systems get, they still don't work where we spend the majority of our time: the great indoors. Tools have been devised that cleverly use Wi-Fi triangulation and "hybrid" GPS (say, GPS coordinates combined with sensor data from a compass, pedometer, and accelerometer), but these are inaccurate and generally unreliable. A company called Byte Light is trying to change this situation with a system that uses LED lighting to provide devices with accurate location data. [9]Byte Light's indoor location system works by controlling the pulses of LEDs so they work in a certain pattern. This pattern is not detectable to the human

eye (it's working in the range of a hundreds of hertz), but can be picked up by the camera in a smartphone or tablet. Using the data gleaned from the LED modulation, the device works with an app and performs client-side calculations to figure out where it is within the structure. Wi-Fi isn't needed so networking is not a problem, and the calculations are performed on the device, so everything happens quickly.

Advantages of LI-FI over WI-FI

High speed connectivity of the rate of 500mbps.

- Li- Fi uses light rather than radio frequency signals so are intolerant to disturbances.
- VLC could be used safely in aircraft without affecting airlines signals.

- Integrated into medical devices and in hospitals as this technology doesn't deal with radio waves, so it can easily be used in all such places where Bluetooth, infrared, Wi-Fi and internet are broadly in use.
- Under water in sea Wi-Fi does not work at all but light can be used and hence undersea explorations are good to go now with much ease.
- There are billions of bulbs worldwide which just need to be replaced with LED's to transmit data.
- Security is a side benefit of using light for data transfer as it does not penetrate through walls.
- On highways for traffic control applications like where Cars can have LED based headlights, LED based backlights, and they can communicate with each other and prevent accidents.
- Using this Technology worldwide every street lamp would be a free data access point.
- The issues of the shortage of radio frequency bandwidth may be sorted out by Li-Fi.